

**ANALYSIS OF DEVICES USED IN THE CRUSHING OF SOLID COMPONENTS
IN THE CRUSHING OF INDUSTRIAL WASTE**

Alimov A.A

PhD, Bukhara engineering-technological institute,
Uzbekistan, Bukhara city, +99897 445-19-00

Juraev J.M.

Trainee researcher, Bukhara engineering-technological institute,
Uzbekistan, Bukhara city, +99891416-95-90
juraevjurabek0707@gmail.com

Abstract

After briquetting, the coal particles are converted into a semi-finished product, a finished product, and a raw material designed to accelerate a process or to carry out a process. Fuel briquettes also have very positive storage properties, take up relatively little space and do not sit in the working area of machinery; dust-free during transportation and packaging, which in turn helps to prevent product waste at all stages; ensures the safety of the working environment, especially when working with flammable substances; increases accuracy by facilitating quantification in a variety of processes.

Key words. Coal briquettes, grinding methods, grinding process, coal fraction, briquetting device, grinder, and crusher.

Introduction

The advantage of these products is that they can be used in their original form and in pieces. Thus, briquetting is the processing of products that can be used as granules through a series of complex processes, subject to several conditions. At the same time, work is being done on the mechanical and thermal performance of briquettes. Depending on the nature of the raw material and the place of use, there are different options for briquetting: press briquetting; Rolling briquetting granulation of powdered substances. Press granulation, analogous to briquetting of substances, involves the formation of a briquette by squeezing it out of a matrix, by pressing it into a certain geometric shape by wetting the powdered coal particles. After briquetting, the coal particles are converted into a semi-finished product, a finished product, and a raw material designed to accelerate a process or to carry out a process. Fuel briquettes also have very positive storage properties, take up relatively little space and do not sit in the working area of machinery; dust-free during transportation and packaging, which in turn helps to prevent product waste at all stages; ensures the safety of the working environment,

especially when working with flammable substances; increases accuracy by facilitating quantification in a variety of processes.

Methods

The advantage of these products is that they can be used in their original form and in pieces. Thus, briquetting is the processing of products that can be used as granules through a series of complex processes, subject to several conditions. At the same time, work is being done on the mechanical and thermal performance of the briquette. Depending on the nature and place of use of raw materials, there are different types of briquetting options: press briquetting; granulation of rolling briquetting powdery substances [1].

Press granulation, analogous to briquetting of substances, involves the formation of a briquette by squeezing it out of a matrix, by pressing it into a certain geometric shape by wetting the powdered coal particles. Briquetting is the process of forming granules by applying pressure to a substance. The maximum value of pressing is 80 MPa (for low pressure machines), 80 to 120 MPa (for medium pressure machines) and 120 MPa (for high pressure machines). The process is performed continuously or intermittently in automatic mode. The most common type in the industry is the rotary machine. In these, the pressing body is a pair of poissons enclosed in two layers around the rotor circumference. Forming (stamping) of coal-based plastic materials is used to give the material a certain shape. Pressing is also widely used in briquetting, in which the matter takes pressure and takes the shape given to it by the matrix. a mass consisting of individual grains and particles is applied to the press. The two-wheel gear grinder has 1 and 2 slow-moving gears with equal speeds w and $1-1.5$ m / s. The starting wheel 1 is connected to the belt by means of a gear extension 3, and the movement to the following wheel 2 is transmitted by a pair of gears of equal diameter. When excessively large pieces fall into the grinder, the wheels overtake the resistance of the springs 5 and move to the side. eliminates excessive tension when the mill roll is punched 5. High-speed wheels are directly connected to the transmission belt ($w \approx 4$ m/sek).

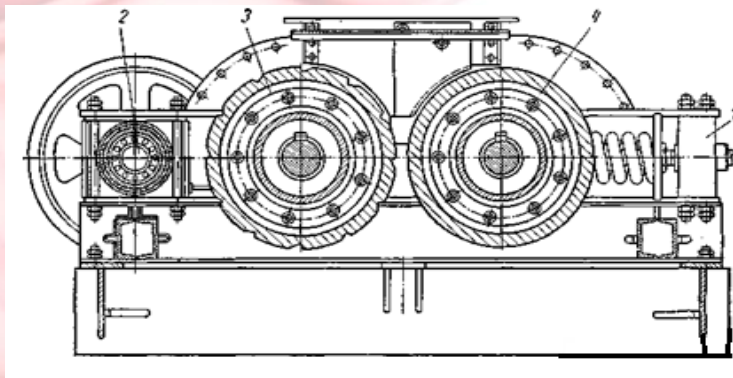

Figure 1. Two-wheel gear grinder: 1 - spring; 2 - gear extension; 3, 4 - gears.

The fine coal fraction is easily crushed. Therefore, under laboratory conditions, coal and bioadditives are ground in a hammer mill. In a hammer grinder, the product is crushed from

the top and pulverized on a belt with a hammer 3 connected to a rotating rotor 4. The product is struck with hammers and collides with the plate 1 surrounding the housing 2. In addition, pieces of material are crushed and crushed. The crushed product passes through the holes in the grill. The briquette can be seen as a large tablet. Coal briquettes are made from coal, lunar particles or previously granulated mass. The production of briquettes from previously granulated material is characterized by high mechanical strength and quality, which increases the efficiency of the equipment. Various district equipment is available for briquetting. Covers all stages from the preparatio of raw materials to the production of the finished product.

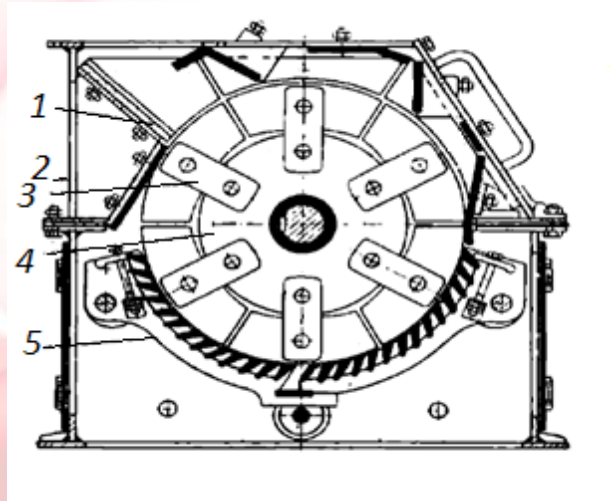

Figure 2. Hammer crusher: 1 - plate; 2 - body; 3 - hammer; 4 - rotor; 5 - grill

The process is performed continuously or intermittently in automatic mode. The most common type in the industry is the rotary machine. In them, the pressing body is made of poissons and fastened in two layers around the rotor circumference. Pressing is one of the main mechanical processes used in briquetting. Its essence is that the coal powder in small fractions is subjected to external pressure under the influence of special press equipment. The main purpose of the process is to bind granular coal fragments and bio admixture in a larger geometric shape. Today, many manufacturing companies use periodic compression presses. This group includes auger presses. The principle of press operation is based on the following basic processes: the raw material is poured into the hopper hopper. Pressing is also widely used in briquetting, in which the matter takes pressure and takes the shape given to it by the matrix. a mass consisting of individual grains and particles is applied to the press. When compressed, the mass of its volume decreases and is removed from the matrix by the narrowed part of the drum. The rotational speed of the auger is very high - 5-20 rpm. The pressure in the cylinder of the auger press is very high and can be 108 Pa or higher. The advantage of these products is that they can be used in their original form and in pieces. Thus, briquetting is the processing of products that can be used as granules through a series of complex processes, subject to several conditions. At the same time, work is being done on the mechanical and thermal performance of the briquette.

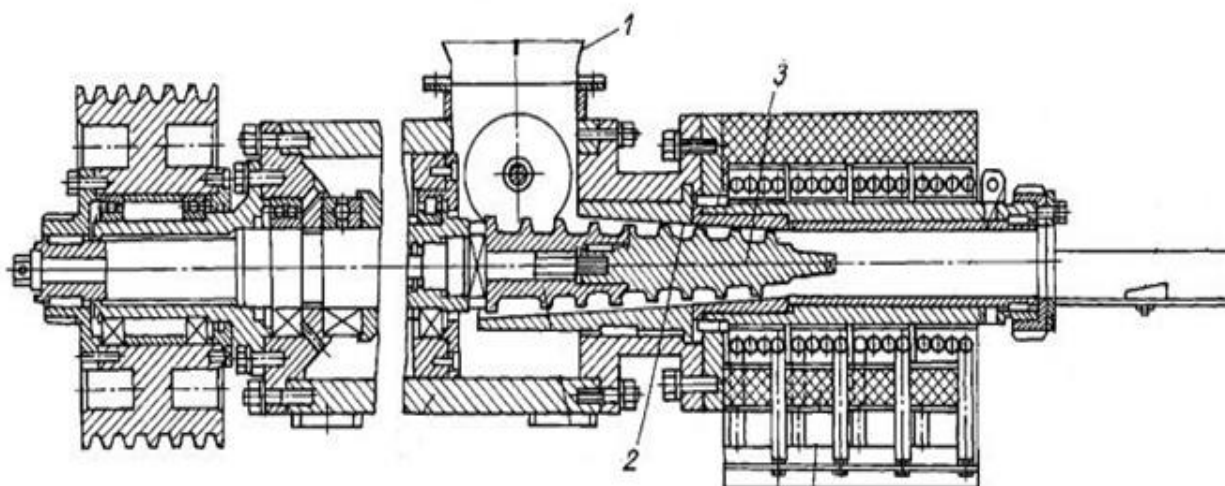

Figure 3. Auger press: 1 - place of raw material loading; 2 - drum; 3 – auger

Conclusion

The power required by the press depends on its design features, productivity, and the pressure it creates. Permanent presses have many advantages over periodic presses. When pressing the same amount of product, continuous presses are much more compact than periodic presses, easy to build and no physical force is applied during service. The use of hydraulic and manual periodic presses increases the working time (15-25%). Compression in auger presses is continuous. The auger press is able to remove the intermolecular gap better than any other type of press.

References

1. M.S. Mirkomilova “Analytical Chemistry” Uzbekistan - 2003
2. K, Akhmedov, R. Sayfiddinov “General and inorganic chemistry” Uzbekistan - 2003
3. Sh.Nazarov and others "Analytical Chemistry" Teacher - 2000
4. N.L. Parpiev “Theoretical bases of inorganic chemistry” Uzbekistan -2000
5. Djuraev X.F., Rasulov Sh. X., Mizomov M.S. “Automation of oil remnant separation process” 24-226 p.
6. 22. Podchukaev, V.A. «Theory of information processes and systems»: uchebnoe posobie / V. A.Podchukaev. - M .: Gardarika-2007